

وزارة التربية والتعليم العالي المديرية العامة للتربية دائرة الامتحانات	امتحانات شهادة الثانوية العامة فرع علوم الحياة	دورة سنة 2003 الاستثنائية
	مسابقة في الفيزياء المدّة : ساعتان	الاسم : الرقم :

*This exam is formed of three obligatory exercises  
in three pages numbered from 1 to 3.  
The use of non-programmable calculators is allowed.*

### **First Exercise (6 points) Graphical study of energy exchange**

Consider an inclined plane that makes an angle  $\alpha$  with the horizontal ( $\sin \alpha = 0.2$ ) and a marble (B) of mass  $m = 100$  g, taken as a particle. We intend to study the energy exchange between the system (marble, Earth) and the surroundings.

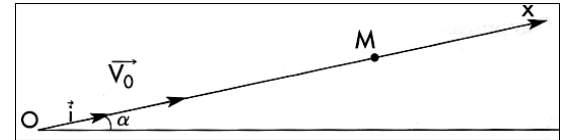

To do that, the marble (B) is given, at the instant  $t_0 = 0$ , the velocity  $\vec{V}_0 = V_0 \vec{i}$  along the line of greatest slope OX. Given  $V_0 = 4 \text{ m}\cdot\text{s}^{-1}$  and  $g = 10 \text{ m/s}^2$ .

The horizontal plane through point O is taken as the gravitational potential energy reference.

**A-** The forces of friction are supposed negligible.

- 1- Determine the value of the mechanical energy M.E of the system (marble, Earth).
- 2- At the instant  $t$ , the marble passes through a point M of abscissa  $OM = x$ . Determine, as a function of  $x$ , the expression of the gravitational potential energy  $P.E_g$  of the system (marble, Earth) when the marble passes through M.
- 3-a) Trace, on the same system of axes, the curves representing the variations of the energies M.E and  $P.E_g$  as a function of  $x$ .

**Scale:** - on the axis of abscissas: 1 cm represents 1 m;

- on the axis of energy: 1 cm represents 0.2 J.

- b) Determine, using the graph, the speed of the marble for  $x = 3$  m.
  - c) Determine, using the graph, the value of  $x_m$  of  $x$  for which the speed of (B) is zero.
- B-1.** In reality, the speed of the marble becomes zero at a point of abscissa  $x = 3$  m. The forces of friction are no longer negligible. Calculate then the work done by the forces of friction between  $x = 0$  and  $x = 3$  m.
2. The system (marble, Earth) thus exchanges energy with its surroundings. In what form and by how much?

## Second Exercise (7 points) Response of an RC series circuit

The object of this exercise is to distinguish the response of an RC series circuit when we apply across its terminals a constant voltage, from its response when it carries a constant current.

### A- Case of a constant voltage

The circuit of the adjacent figure allows us to charge the capacitor of capacitance  $C = 10 \mu\text{F}$  through a resistor of resistance  $R = 100 \text{ k}\Omega$ , under a constant voltage  $E = 9\text{V}$ . Take the instant  $t = 0$  the instant when the switch  $K$  is closed.

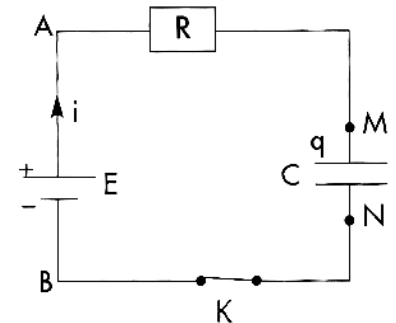

1- Denote by  $u_C = u_{MN}$ , the instantaneous value of the voltage across the terminals of the capacitor.

a- Show that the differential equation in  $u_C$  is of the form:

$$u_C + RC \frac{du_C}{dt} = E$$

b- Knowing that the solution of this equation has the form:  $u_C = A(1 - e^{-\frac{t}{\tau}})$  determine  $A$  and  $\tau$ .

c- Trace the shape of the curve that gives the variation of  $u_C$  as a function of time.

2- a- Determine the expression of the voltage  $u_R = u_{AM}$  as a function of time.

b- Trace, on the same system of axes, the shape of the curve giving the variation of  $u_R$  as a function of time.

3- What is the value of the interval of time  $t_A$  at the end of which  $u_C$  becomes practically  $9\text{V}$ ?

### B- Case of a constant current

The preceding capacitor being discharged is to be recharged through the same resistor by a generator giving a constant current  $I_0 = 0.1 \text{ mA}$ .

1-a- Show that the charge  $q$  can be written, in SI, in the form  $q = 10^4 \times t$ .

b- The voltage  $u_R = u_{AM}$  across the resistor remains constant. Determine its value.

c- Trace the shape of the graph representing  $u_R$ .

2-a- Determine the expression of the voltage  $u_C = u_{MN}$  as a function of time.

b- Trace the shape of the graph representing  $u_C$ .

c- Determine the time interval  $t_B$  needed for the voltage  $u_C$  to attain the value  $9 \text{ V}$ .

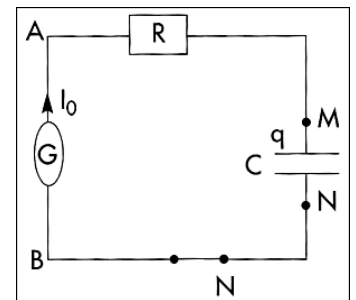

### C- Conclusions

1- Using the preceding graphs, specify the case where the voltage across the capacitor attains, in the steady state, a limiting value.

2- A camera is equipped with a flash that is formed of the preceding RC circuit. We intend to take the largest number of photos in a given time interval. To do so we have to charge the capacitor. Which one of the two preceding charging modes is more convenient? Why?

### Third exercise (6 1/2 points) **The isotope ${}^7_3\text{Li}$ of lithium**

As all the other chemical elements, the isotope  ${}^7_3\text{Li}$  has properties that distinguish it from other chemical elements.

The object of this exercise is to show evidence of some properties of the isotope  ${}^7_3\text{Li}$ .

#### **A- Emission spectrum of the lithium atom**

The adjacent figure represents the energy levels of the lithium atom.

1- Calculate, in joule, the energy ( $E_1$ ) of the atom when it is in the ground state and ( $E_5$ ) when it is in the fifth state.

2- During the downward transition (de-excitation) from different energy levels to the ground level, the lithium atom emits some radiations.

- Calculate the highest and the lowest frequency of the emitted radiations.
- The corresponding emission spectrum is discontinuous. Why?

3- The lithium atom, being in the ground state, captures:

- a photon whose associated radiation has a wavelength of  $\lambda = 319.9$  nm. Show that the atom absorbs this photon. In what level would it be?
- a photon of energy 6.02 eV. An electron is thus liberated. Calculate, in eV, the kinetic energy of that electron.

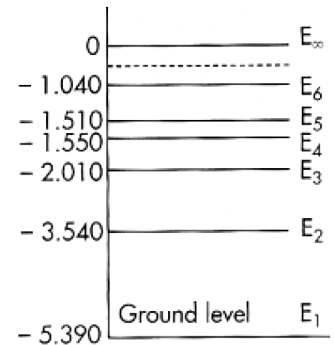

#### **B- Nuclear reaction**

A nucleus  ${}^A_Z\text{X}$ , at rest, is bombarded by a proton carrying an energy of 0.65 MeV; we obtain two  $\alpha$  particles.

- Is this nuclear reaction spontaneous or provoked? Justify your answer.
- Determine the values of Z and A by applying the convenient conservation laws. Identify the nucleus X.
- Calculate the mass defect due to this reaction and deduce the corresponding energy liberated.
- Knowing that the two obtained  $\alpha$  particles have the same kinetic energy E. Calculate E.

**Given:**  $h = 6.62 \times 10^{-34} \text{ J} \cdot \text{s}$ ;  $c = 3 \times 10^8 \text{ m} \cdot \text{s}^{-1}$ ;  $1 \text{ eV} = 1.6 \times 10^{-19} \text{ J}$ ;  
 $1 \text{ u} = 931.5 \text{ MeV}/c^2$ ;  
mass of the nucleus of lithium:  $m(\text{Li}) = 7.01435 \text{ u}$ ;  
mass of the  $\alpha$  particle:  $m(\alpha) = 4.00150 \text{ u}$ ;  
mass of a proton:  $m_p = 1.00727 \text{ u}$ .